

BALLUFF

For efficient
automation

PRODUCTS + NEWS



B *innovating automation*

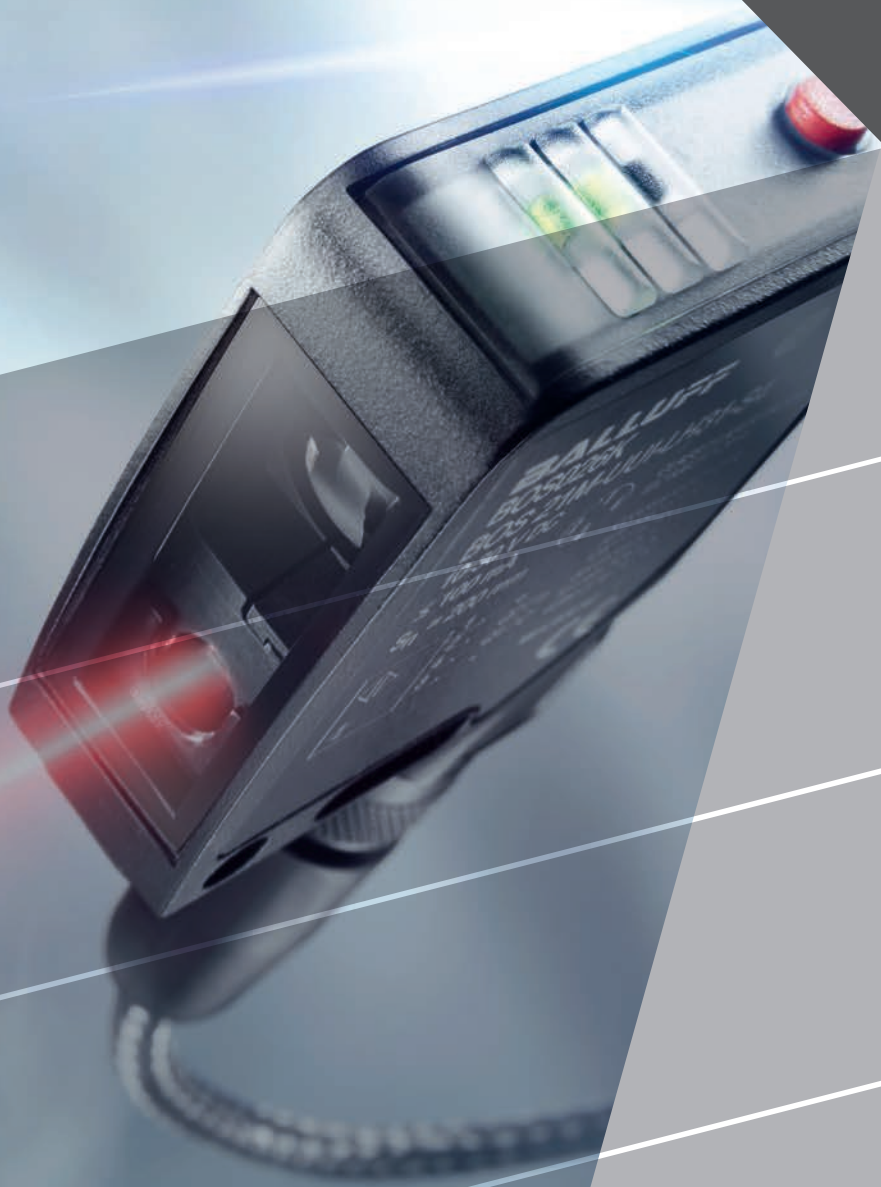

CONTENTS

4
SENSORS



- 6 Inductive Factor 1 sensors newest generation
- 8 Photoelectric laser precision sensor
- 10 Continuous level measurement using guided radar sensors

12
MACHINE VISION AND
OPTICAL IDENTIFICATION



- 14 Vision solutions – industrial camera

16
SAFETY

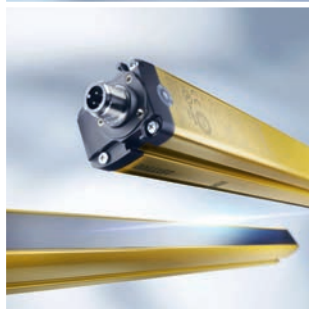

- 18 Galvanically isolated sensor/actuator hub

20
INDUSTRIAL NETWORKING



- 22 IO-Link hub for eight analog input signals
- 24 IP69 network modules for demanding environments
- 26 Universal IO-Link interface

28
ACCESSORIES

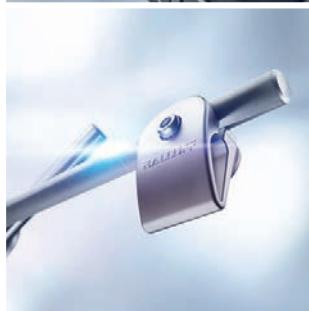

- 30 Coolant and lubricant resistant machine lights

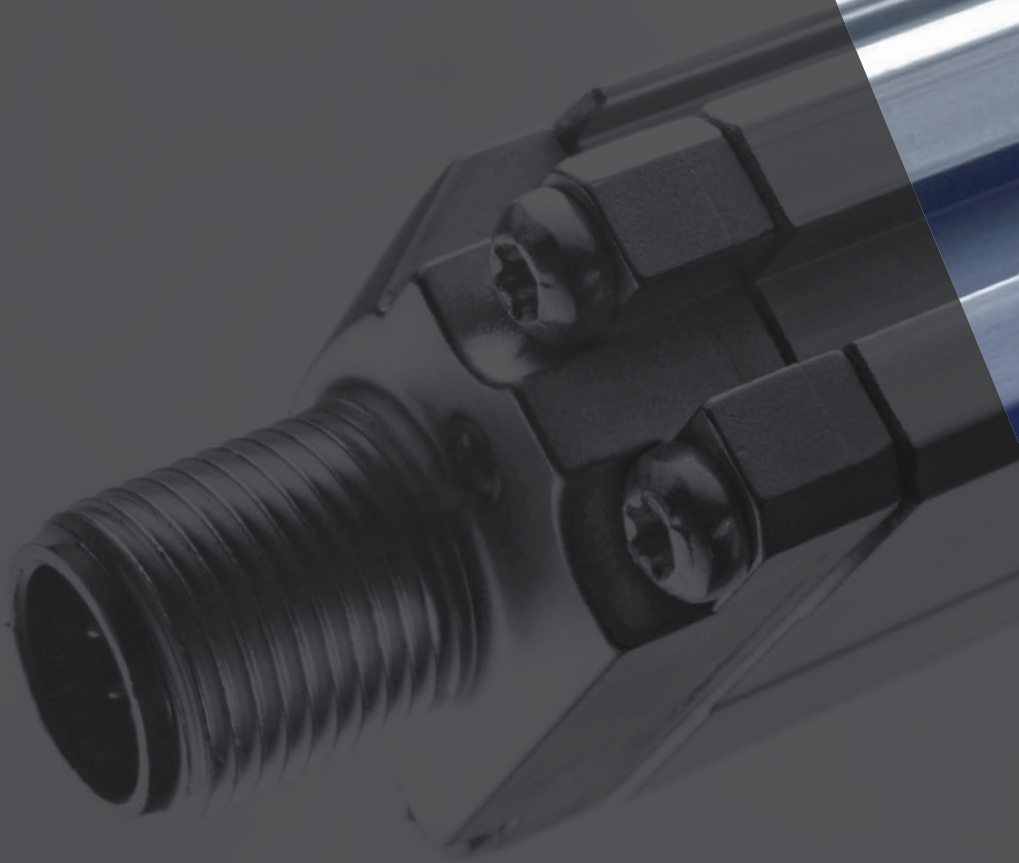

Comprehensive solutions for industrial automation

SENSORS



innovating automation

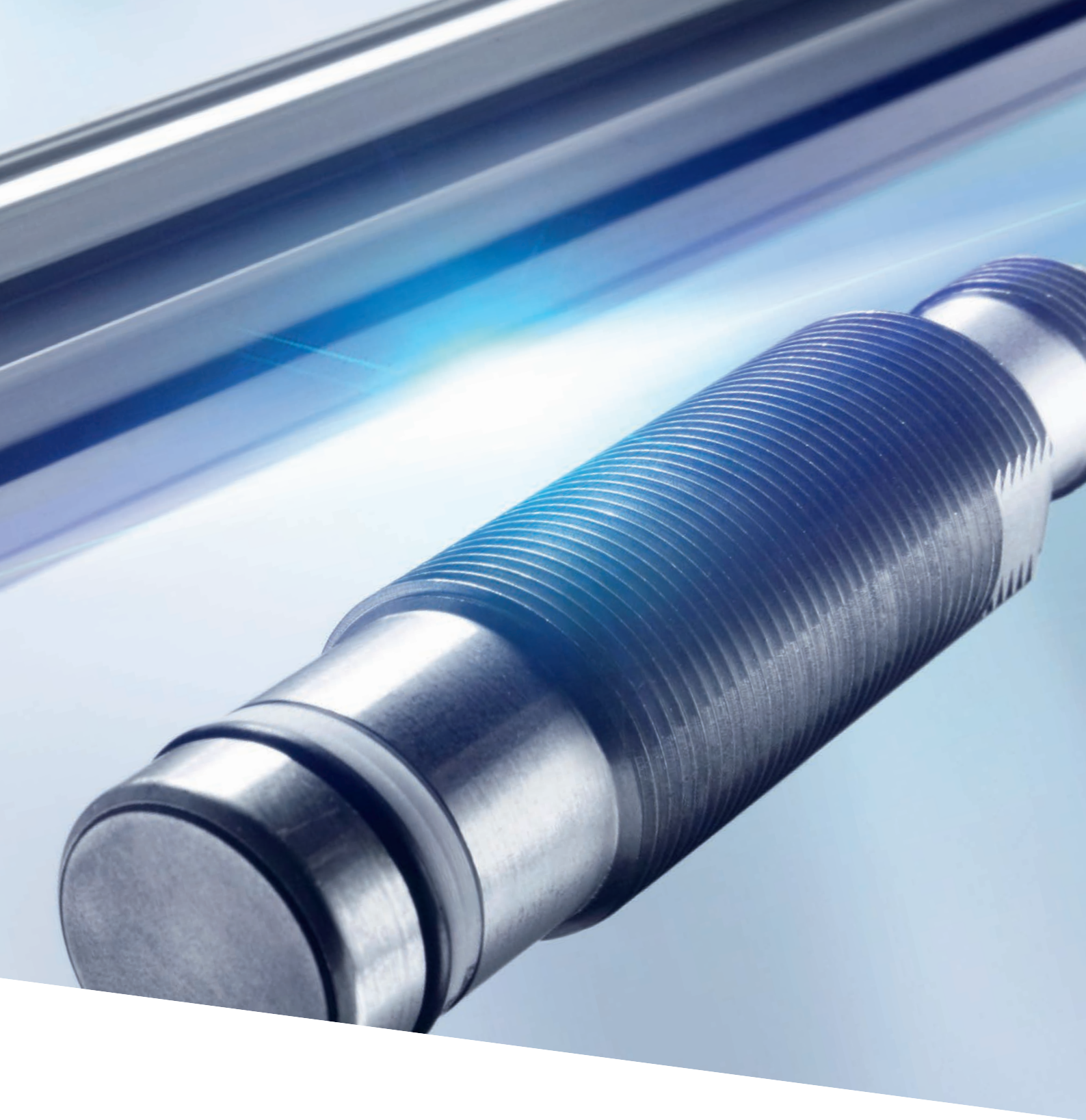

In the field of sensor technology, Balluff handles the entire range of technological diversity with its various operating principles. We provide you with high-quality sensors for any application or requirement: from distance measurement to object detection and level, temperature and pressure monitoring for everyday industrial uses as well for tough applications in critical environments.

Our quality management regime is DIN EN ISO 9001:2015 certified. All Balluff sensors are tested in our in-house, accredited laboratory. They meet regional as well as international standards and are used throughout the world.

Your Balluff solutions

- Inductive sensors
- Photoelectric sensors
- Capacitive sensors
- Magnetic field sensors
- Ultrasonic sensors
- Cam switches
- Magnetostrictive sensors
- Magnetic encoders
- Radar sensors
- Inclination sensors
- Pressure transmitters
- Temperature sensors

Material-neutral object detection with identical switching distance

INDUCTIVE FACTOR 1 SENSORS NEWEST GENERATION

Being able to detect objects made of different materials – e.g. steel, aluminum or brass – without a reduction factor offers decisive advantages especially in applications where materials vary or alloys need to be detected at greater switching distances. The new Factor 1 sensors are magnetic field immune, so that they can perform all the functions even in the presence of electromagnetic fields, such as in induction hardening and welding areas.

Features

- Generous switching distance for iron and alloys
- Magnetic field immune and PTFE coated for performance even in harsh environments
- IP68 protection rating and expanded temperature range for the most demanding requirements
- Can be used flexibly and with high precision even when objects are changing

INDUCTIVE
FACTOR 1
SENSORS



	BES05AK	BES05AM	BES05AH	BES05AJ	BES05AL
Design	M18 × 1	M18 × 1	M18 × 1	M18 × 1	M18 × 1
Installation type	Flush	Non-flush	Flush	Flush	Non-flush
Output	PNP, NO	PNP, NO	PNP, NO	PNP, NO	PNP, NO
Switching distance	8 mm	12 mm	8 mm	8 mm	12 mm
Operating voltage	24 V DC	24 V DC	24 V DC	24 V DC	24 V DC
Switching frequency	2500 Hz	2500 Hz	2500 Hz	2500 Hz	2500 Hz
Degree of protection	IP68	IP68	IP68	IP68	IP68
Approval/Conformity	CE, cULus	CE, cULus	CE, cULus	CE, cULus	CE, cULus
Ambient temperature	-40...+85 °C	-40...+85 °C	-40...+85 °C	-40...+85 °C	-40...+85 °C
Housing material	Brass, PTFE coated	Brass, PTFE coated	Brass, PTFE coated	Brass, PTFE coated	Brass, PTFE coated
Sensing surface material	PBT	PBT	PBT, PTFE coated	PBT	PBT

For product finder and more technical details:
www.balluff.com/go/inductive-sensors

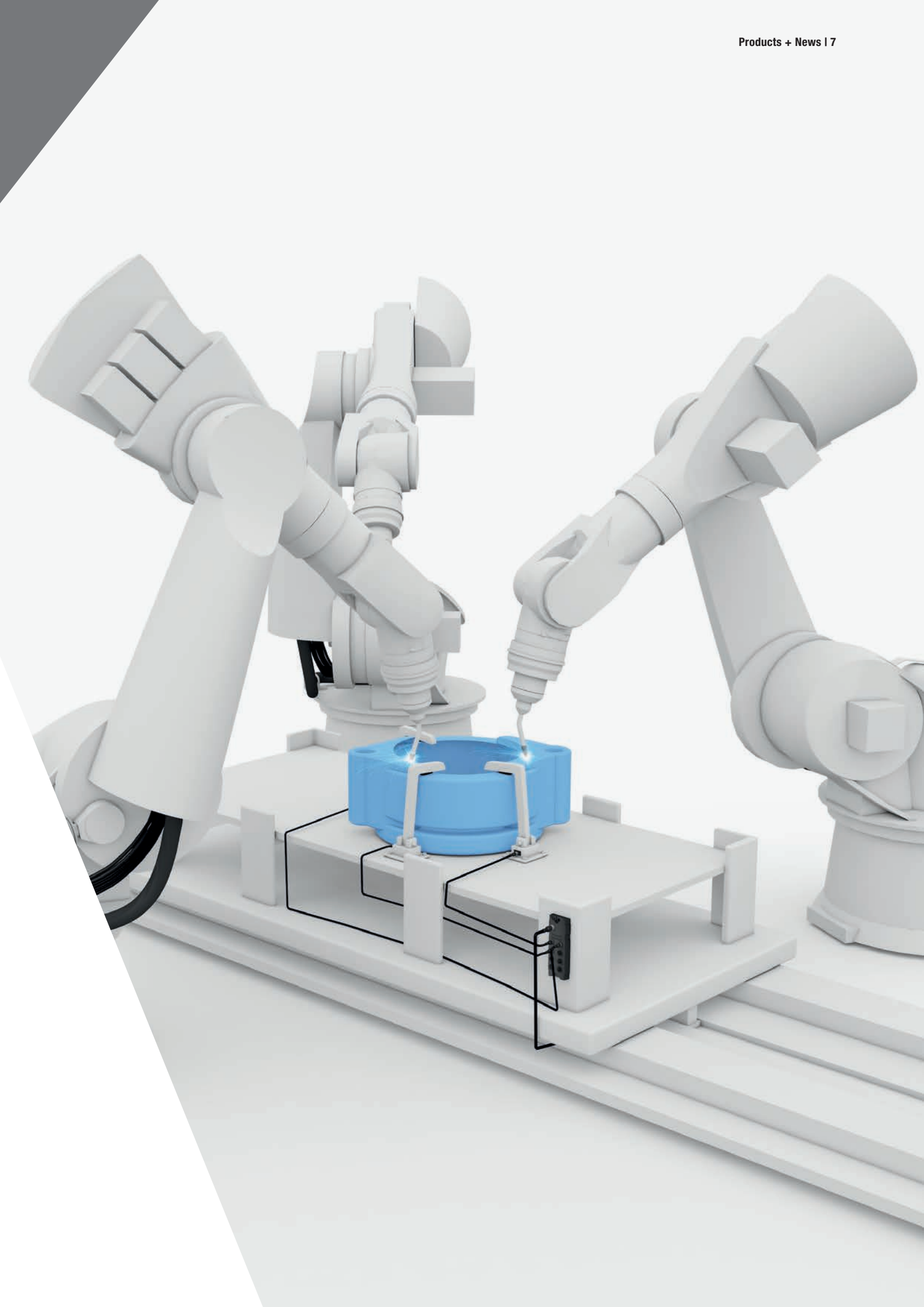

Object detection at the highest level

PHOTOELECTRIC LASER PRECISION SENSOR



Reliably detecting the smallest details has always been one of the great challenges for sensors. This is where the new BOS 21M photoelectric sensor shows its class-leading performance. It impresses with outstanding precision in all detection tasks and convinces with numerous useful additional features.

Different detection and processing modes enable you to detect even complicated objects with exactness. And when other sensors reach their limits, the laser precision sensor handles even complex applications with aplomb. You can choose between two different sensor modes: in background suppression the sensor is taught to detect the target object and in background evaluation mode the sensor looks for the background. This means the BOS 21M HPL even detects any reflective or shiny part with extreme reliability.

Both sensor modes ensure maximum precision and reliability. You can set the modes depending on the object easily via

IO-Link, so that you are always using the best detection method. And in critical environments with much interfering light the intelligent ambient light, suppression feature improves your results. This especially helpful sensor function filters out undesirable influences so you prevent erroneous switching and the resulting system shutdowns.

Features

- Extremely precise object detection even in difficult environments
- Selectable background suppression or background evaluation modes
- Intelligent data pre-processing right in the sensor
- Smart, efficient diagnostics capabilities

DIFFUSE SENSOR WITH BACKGROUND SUPPRESSION



	BOS026K
Principle	Diffuse sensor with background suppression
Detection range	30...200 mm
IO-Link functions (IO-Link Version 1.1)	<ul style="list-style-type: none"> ■ Selectable detection modes – Background suppression or background processing ■ Intelligent ambient light suppression and adjustable hysteresis ■ Flexible, freely configurable counting function ■ Sensor condition diagnostics, plausibility check ■ Additional service functions, output configuration, time functions
Light type, laser class	Laser red light, Laser Class 1
Light spot size	1 × 3 mm (at 30 mm), 0.5 × 1.5 mm (at 200 mm)
Switching distance deviation	1 % typ. (20 % to 90 % reflectivity)
Degree of protection	IP67
Approval/Conformity	CE, EAC
Ambient temperature	-5...+55 °C
Housing material	Die-cast zinc, aluminum, glass
Connection	M12 male, 4-pin

With a broad range of applications for solids and liquids

CONTINUOUS LEVEL MEASUREMENT USING GUIDED RADAR SENSORS

You can use guided radar sensors for level measurement in liquids and solids as well as for measuring separating layers. The guided radar pulses along the probe ensure precise and stable measurement even with dust-forming and foamy media. And all this with a measuring length of up to 75 m. This means our solutions open up a wide range of applications for you: from small filler tanks to large storage tanks.

Thanks to their measuring principle and mechanical design, guided radar sensors are predestined for harsh environments. In hygienic models they handle measuring tasks in pharmaceutical and food applications. The certified sensors can also be used in explosion hazard areas as typically found in refineries and chemical processing.

Features

- Precise, absolute level measurement
- Suitable for solids and liquids
- Wear- and maintenance-free
- High durability and long service life
- Flexible installation and ease of handling
- SIL2 certified for hygienic applications and explosion hazard areas



RADAR SENSORS

	BMD001R	BMD001Y	BMD001M
Analog output	4...20 mA	4...20 mA	4...20 mA
Interface	HART	HART	HART
Repeatability absolute	±1 mm	±1 mm	±1 mm
Non-linearity max.	±2 mm	±2 mm	±2 mm
Cycle time min.	500 ms	500 ms	500 ms
Operating voltage	16...35 V DC	16...35 V DC	16...35 V DC
Ambient temperature	-40...+80 °C	-40...+80 °C	-40...+80 °C
Housing material	Stainless steel	Stainless steel	Stainless steel
Degree of protection	IP66, IP68	IP66, IP68	IP66, IP68
Approval/Conformity	CE, EAC	CE, EAC, ATEX, TÜV, IECEx	CE, EAC, FDA conformal
Connection	Terminal clamp, M20 fitting	Terminal clamp, M20 fitting	Terminal clamp, M20 fitting

For product finder and more technical details:
www.balluff.com/go/radar-sensors



Industrial image processing for
reliable detection and recording

MACHINE VISION AND OPTICAL IDENTIFICATION

 *innovating automation*

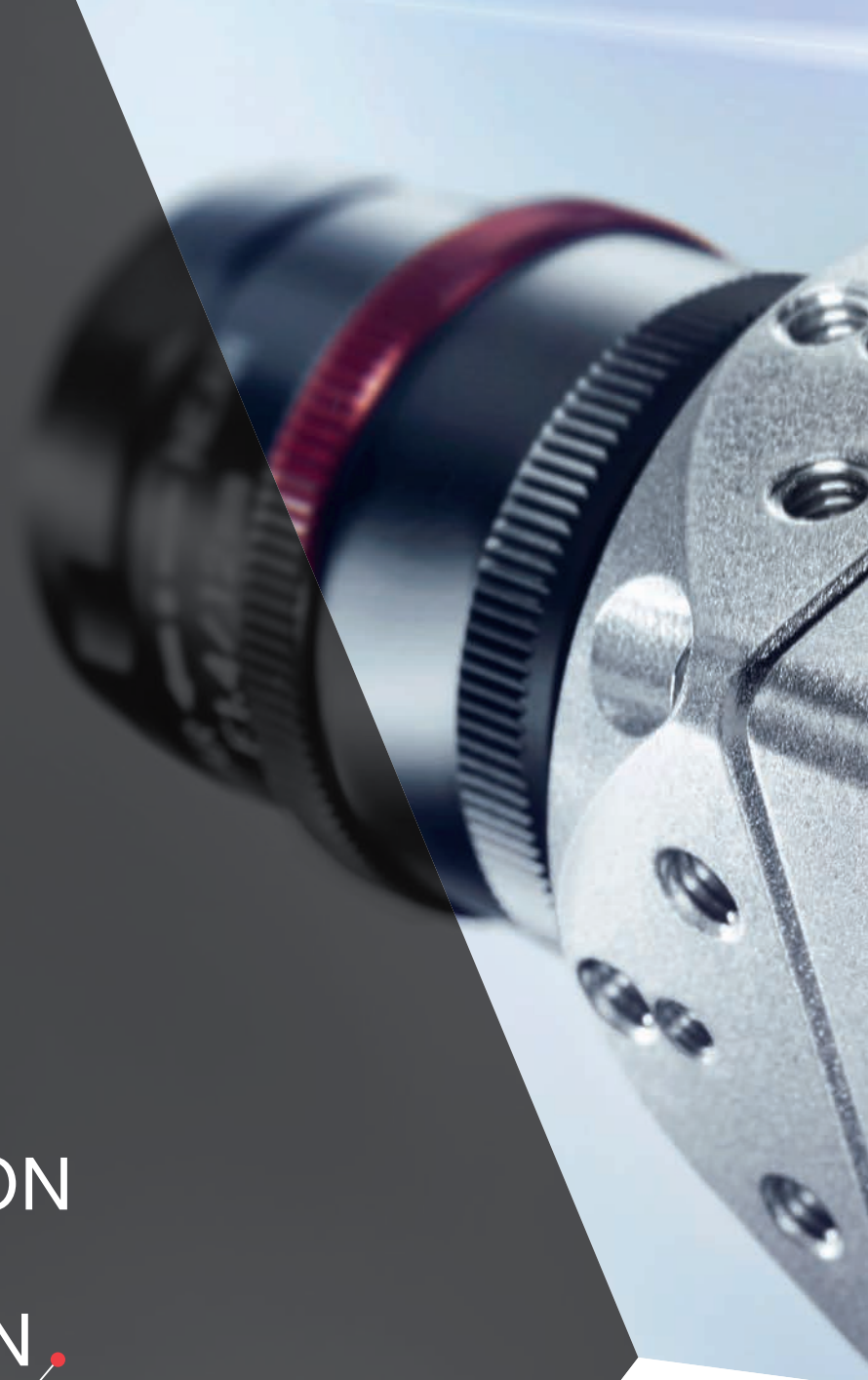



The demands on modern production equipment are high: they must be extremely productive and flexible – while achieving maximum quality. Our vision solutions for industrial image processing meet just such requirements. They reliably detect errors, check quality and are suitable for reliable reading and verification of 1D and 2D barcodes and detect plain text. This gives you versatility and a powerful range of applications for visual quality inspection, identification and positioning tasks.

The sensors are extremely flexible – for parts checking in assembly or parts tracking in production. Their standardized interface means the devices are simple to integrate and easy to use.

Your Balluff solutions

- Machine vision
- Optical identification

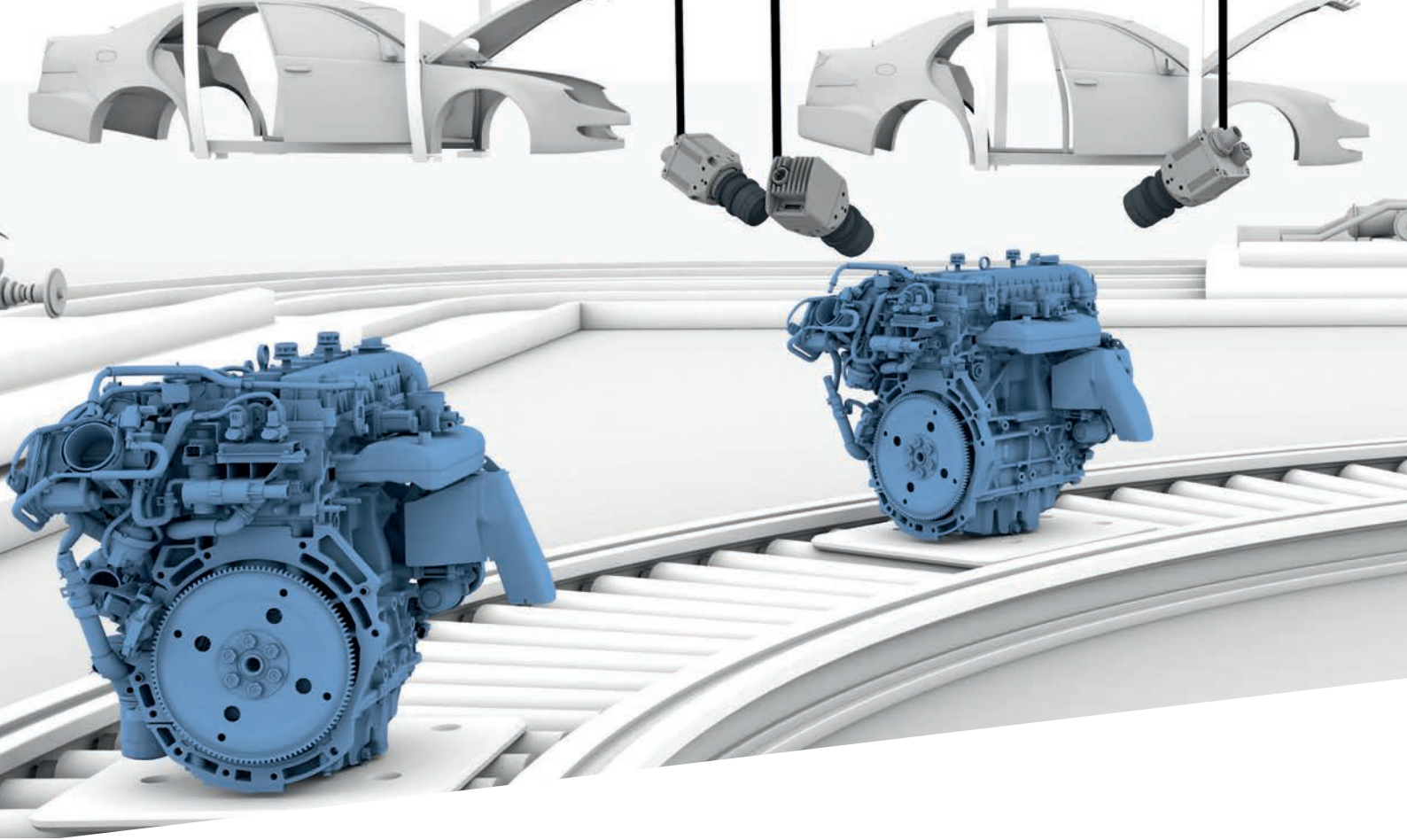

High-performance industrial system with BVS Cockpit and industrial controller

VISION SOLUTIONS – INDUSTRIAL CAMERA

With our industrial cameras you create outstanding images and profit from especially fast image transmission. The simple BVS Cockpit user interface lets you operate the industrial camera with no prior knowledge and configure it to your individual requirements. Select between color or black-and-white and four different image resolutions. This offers you great flexibility in installation because wherever you locate the compact camera, its high resolution guarantees tack sharp images and the best inspection results.

For use with the BVS Cockpit system, our industrial cameras need an industrial controller with integrated software. Since you can connect several cameras to a controller at the same time, multiple inspections are also possible. One inspection can be carried out from different angles of view simultaneously. This not only increases the quality of the inspection, but is also especially economical, since you can check for different things and process their results simultaneously using the industrial controller.

Features

- Flexible, application-optimized use of multiple industrial cameras
- Optimized image data processing
- Fast data processing based on the user-friendly BVS Cockpit interface
- Standardized process interfaces TCP/IP/UDP or Profinet
- Remote control in networked locations

For product finder and more technical details:
www.balluff.com/go/machine-vision

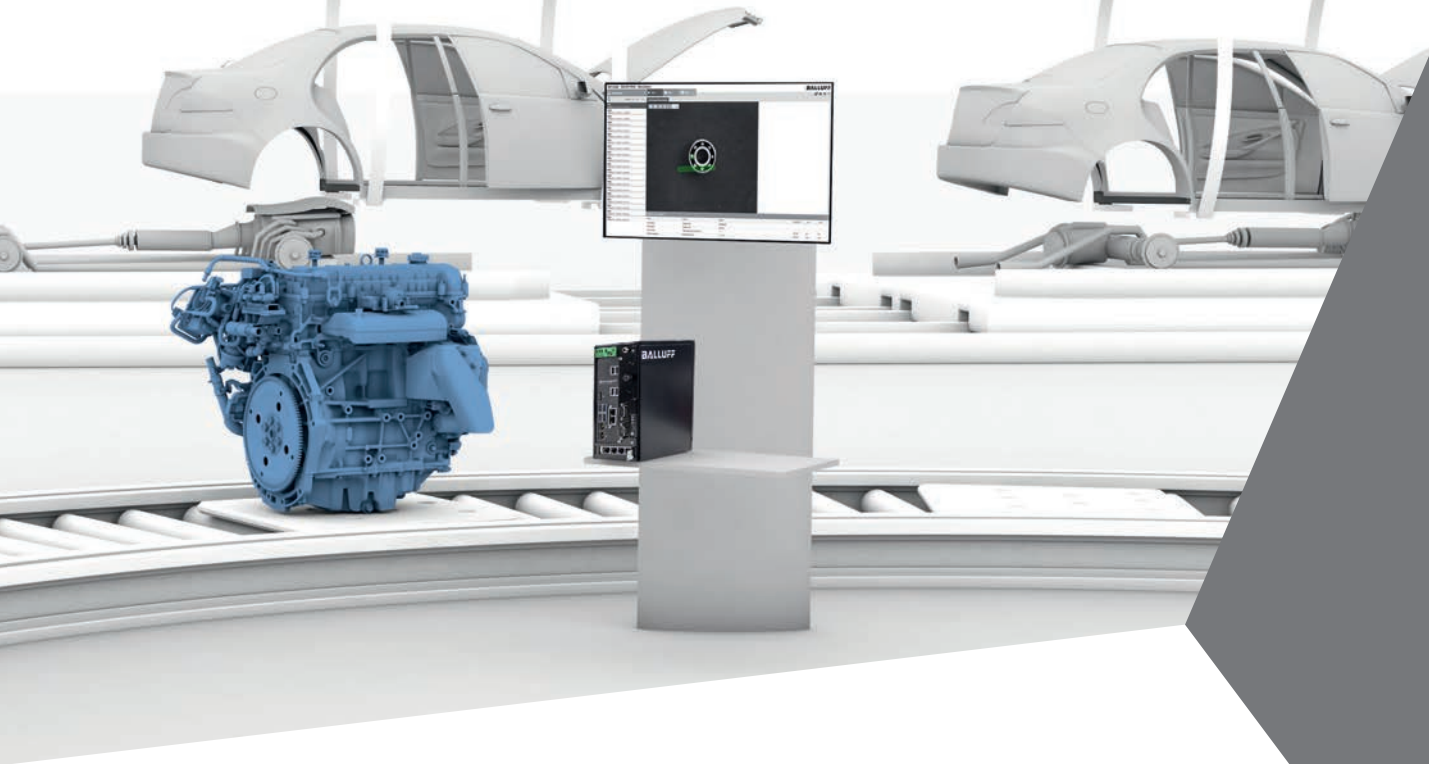

INDUSTRIAL
CAMERA

SMARTVISION
CONTROLLER

Monochrome, 1.6 MP	BVS002H	BVS002T
Color, 1.6 MP	BVS002J	BVS002U
Monochrome, 3.2 MP	BVS002K	BVS002W
Color, 3.2 MP	BVS002L	BVS002Y
Monochrome, 5.1 MP	BVS002M	BVS002Z
Color, 5.1 MP	BVS002N	BVS0030
Monochrome, 12.4 MP	BVS002P	BVS0031
Color, 12.4 MP	BVS002R	BVS0032
Dimension	68.7 × 40 × 40 mm	37.7 × 40 × 40 mm
Sensor chip	CMOS	CMOS
Lens	C-Mount	C-Mount
Data interface	GigE-Vision	USB3-Vision
Digital interface	4 inputs, 4 outputs	2 inputs, 4 outputs
Operating temperature	0...+45 °C	0...+45 °C
Housing material	Aluminum, coated	Aluminum, coated
Weight	157 g	94 g

	BAE0103
Description	SmartVision Controller
Dimension	192 × 229 × 88 mm
Power supply	15...24 V
Operating system	Linux, BVS-Cockpit
Processor	i7 – 6700TE
RAM	16 GB DDR4
Hard drive	256 GB SSD
Interfaces	2 × LAN 4 × GIGE-LAN 4 × USB3 4 × USB2 2 × Profinet
Application software	BVS-Cockpit with HALCON license
Operating temperature	+10...+50 °C
Housing material	Sheet steel, coated
Weight	2700 g

Not included: Lens, connection cable and other accessories, see www.balluff.com

Power supply and mounting system included in scope of delivery

Safety with Balluff quality

SAFETY

 *innovating automation*

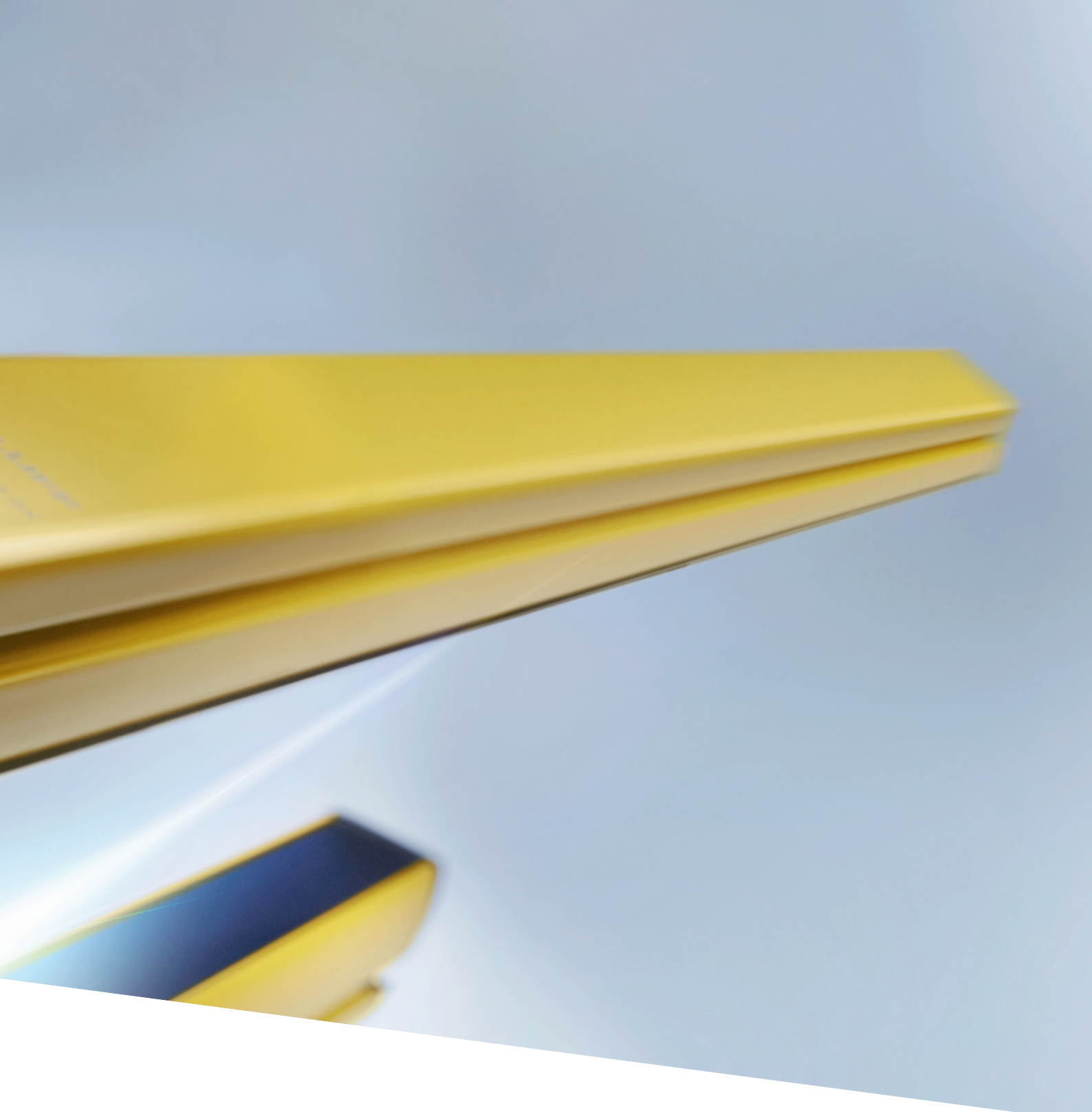

Automation requires safety. And safety is based on reliability. The Balluff safety concept consists of products and solutions that fulfill their tasks over the course of years, with the same reliability and precision. With Safety over IO-Link from Balluff you enjoy the proven benefits of IO-Link for the safety of people and equipment as well. By linking automation technology and safety technology, you get full machine safety in one system because IO-Link communicates down to the last meter and provides both sensor/actuator details as well as safety information.

Your Balluff solutions

- Safety I/O block
- Protection devices

All-in-one solution with safely interruptible actuator segment

GALVANICALLY ISOLATED SENSOR/ACTUATOR HUB

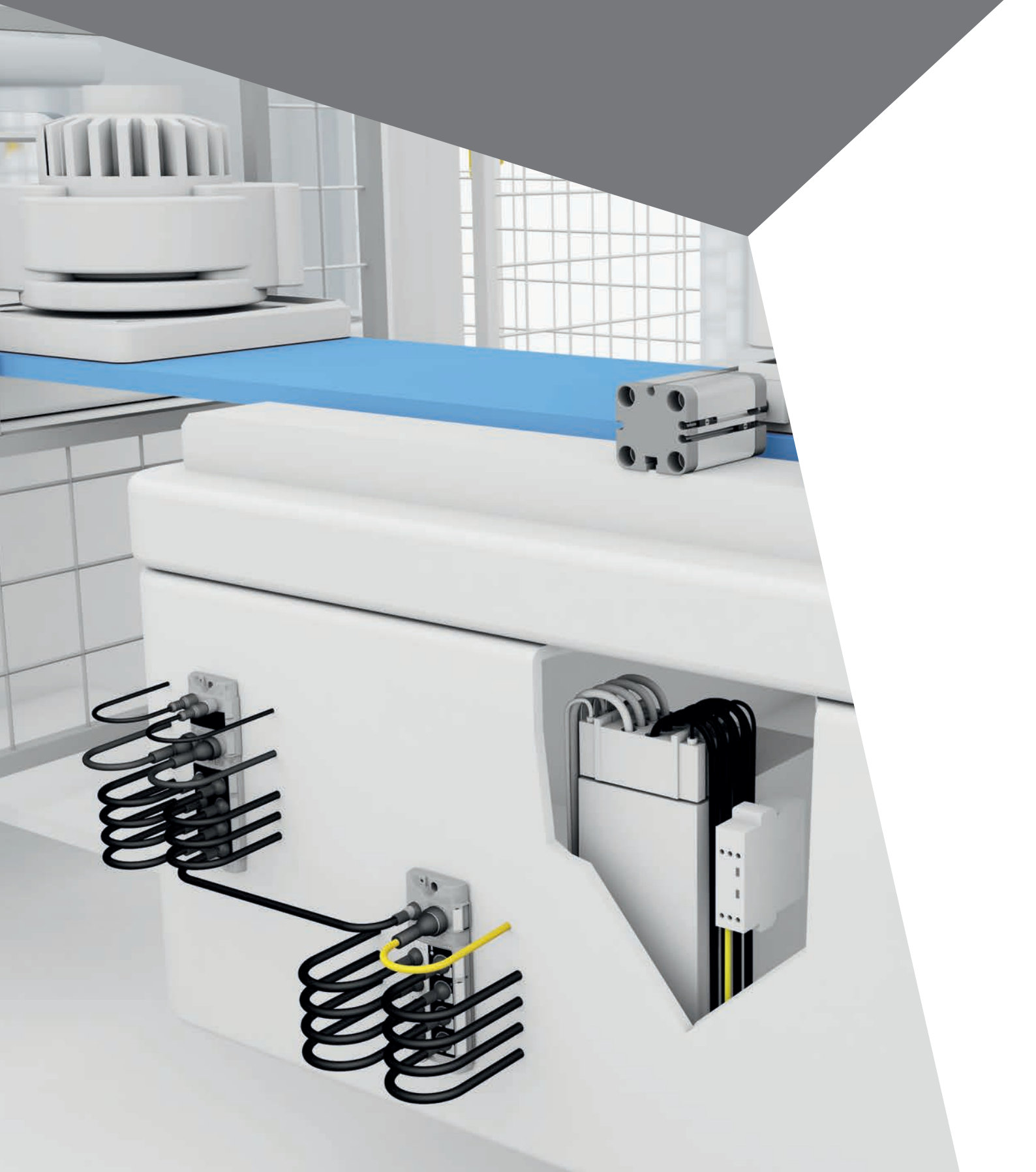

The BNI IOL-355 galvanically isolated sensor/actuator hub offers you an all-in-one solution for connecting both sensors and actuators. With this innovative block you can operate up to eight digital in- and outputs. At the same time, you can safely turn off the actuator segment via its separately switchable safety circuit because the IO-Link I/O hub is divided into two galvanically isolated segments.

To deactivate the supply voltage to the actuator segment you only need an external safety device. Now you can also achieve safety functions up to SIL2 per EN 62061. Another highlight: if the IO-Link connection is interrupted, the outputs assume predefined states until the connection is restored.

Features

- Connect in- and output signals to just one block
- Safely switch off output signals thanks to galvanic isolation
- Easy diagnostics via IO-Link and status LEDs
- Rugged metal IP67 housing for harsh environments



IO-LINK BLOCKS FOR SAFETY APPLICATIONS

	BNI00CL
Interface	IO-Link 1.1
Transfer rate	COM3 (230.4 kBaud)
Response time	1 ms
PL (EN ISO 13849-1)	d
SIL CL (EN/IEC 62061)	2
Power supply	19.2...30 V DC (per EN 61131-2)
Degree of protection	IP67*
Approvals	CE, TÜV, UL-File E319845, Vol. 1, Sec. 1
Ambient temperature	-5...+55 °C
Number of inputs	8
Number of outputs	8
Total current (actuator, sensor)	9 A

*when connected

Reliable information exchange across all levels

INDUSTRIAL NETWORKING

 *innovating automation*



The demands on industrial networking continually increase: The rising quantities of data and ever more complex communication require high-performance components that can reliably transport the information across all production levels. This is especially true if high protection types, robustness, use at high temperatures or special interfaces and connections for maximum security are needed.

With the intelligent combination of high-performance industrial networking technology and the IO-Link communication standard, Balluff makes flexible and smooth communication in the most varied application scenarios possible.

Your Balluff solutions

- Network modules
- I/O modules
- Switches
- IO-Link memory modules
- Inductive couplers

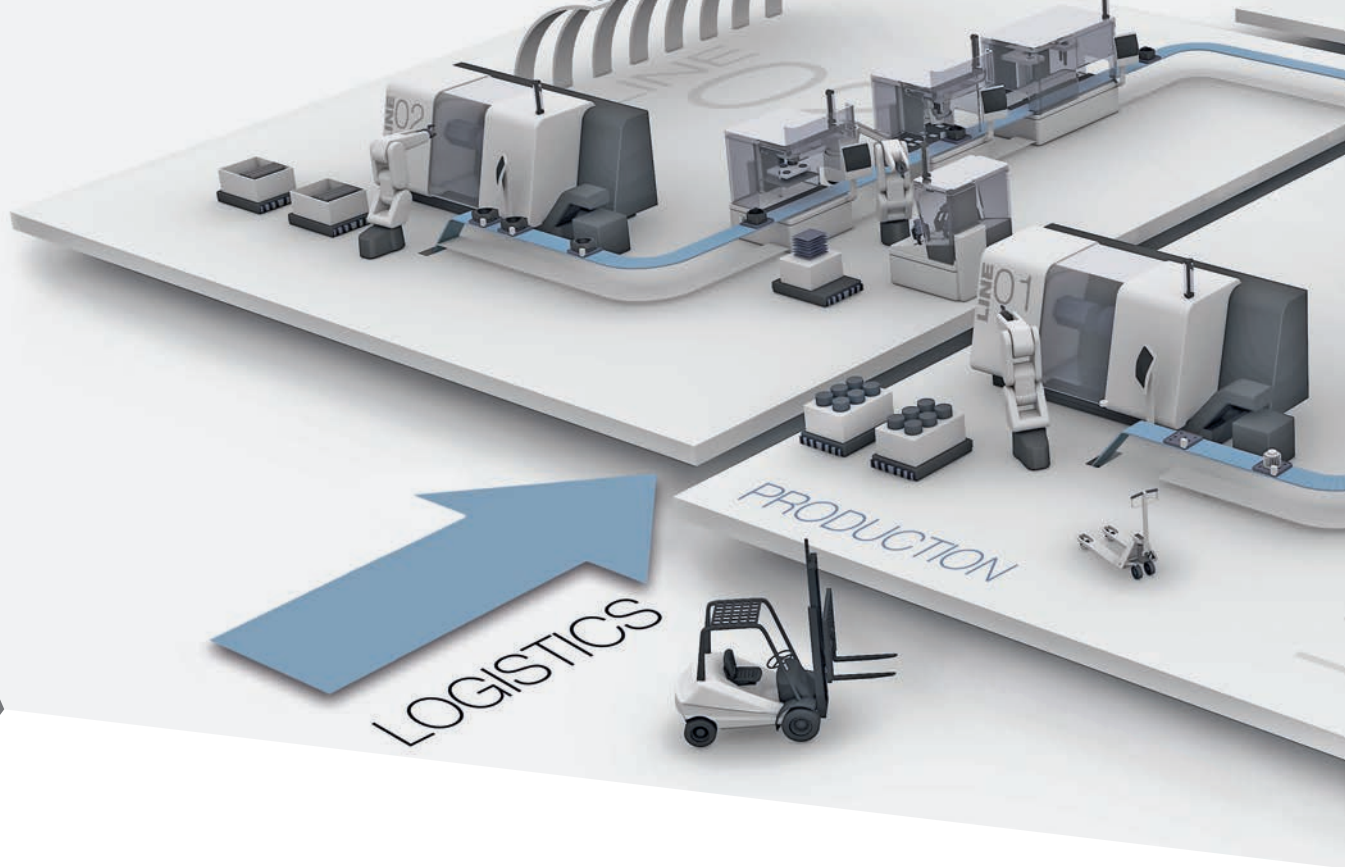

Reduce analog value volume and save costs

IO-LINK HUB FOR EIGHT ANALOG INPUT SIGNALS

In most equipment and machines, analog signals make up around ten per-cent of the total data volume but connecting and incorporating them involves great expense for one simple reason: Installation requires shielded cable and the controller requires expensive multi-channel input modules. Not so with the IO-Link hub, because it converts up to eight analog input signals into digital signals and passes them on to the IO-Link master. It does this with maximum signal variance, which makes the mixing of different current and voltage interfaces on a module possible.

Features

- Converts eight analog input signals
- Each port can be configured as an input for a voltage/current signal, Pt sensor or thermocouple
- Various current/voltage interfaces: 0...10 V, 5...10 V, -10...+10 V, 0...5 V, -5...+5 V, 0...20 mA and 4...20 mA
- Freely configurable resolution: 10...16 bits
- High protection rating for harsh ambient conditions

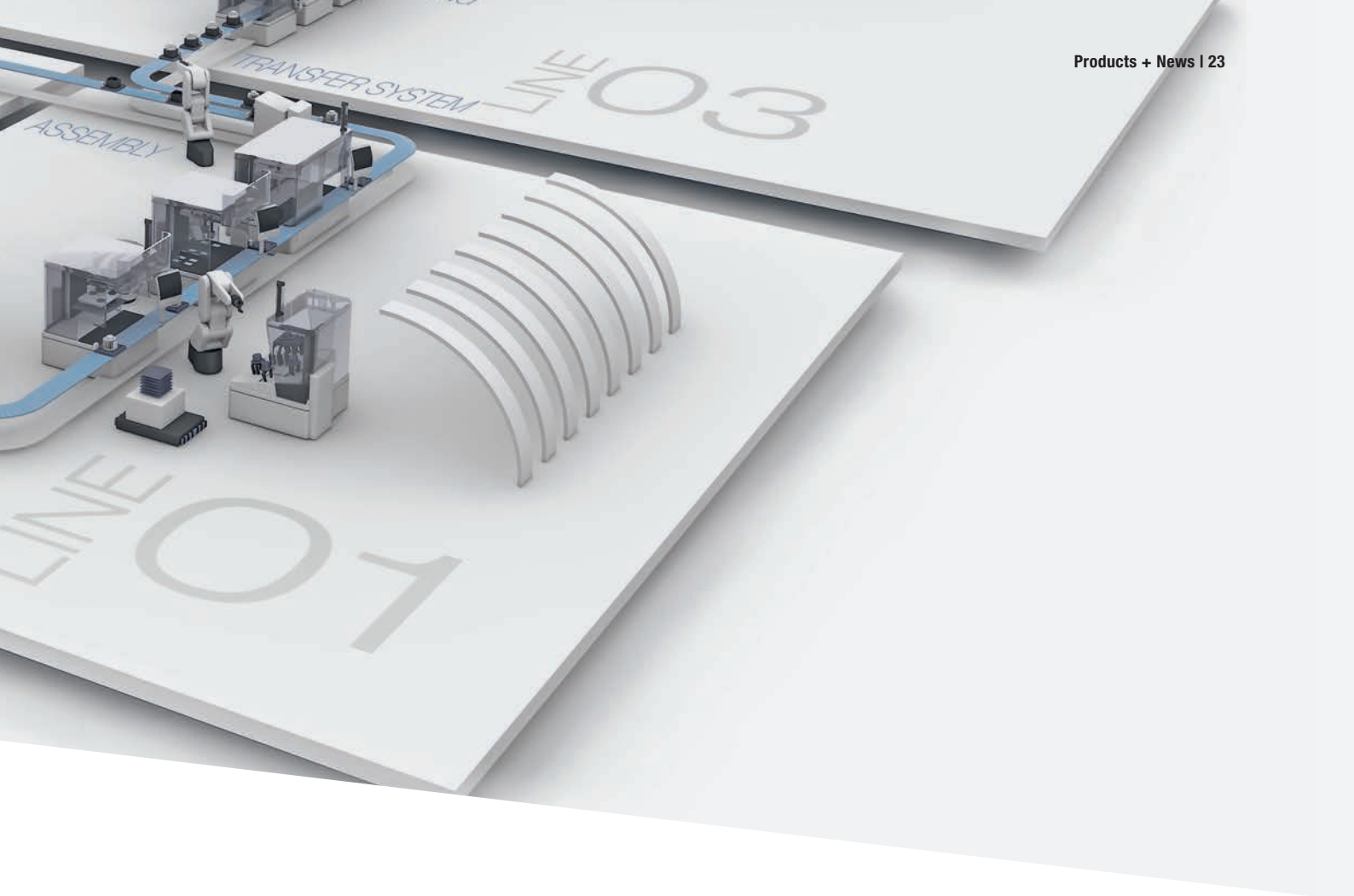

IO-LINK SENSOR/ACTUATOR HUBS

	BNI00AJ
Communication	IO-Link 1.1
Design	8 × analog inputs
Operating voltage	18...30.2 V DC, per EN 61131-2
Connection: Communication	M12 male, A-coded
Current consumption without load	≤ 80 mA
Connection: analog ports	8 × M12 female, 5-pin
Voltage interfaces	0...10 V, 5...10 V, -10...+10 V, 0...5 V, -5...+5 V
Current interfaces	0...20 mA, 4...20 mA
Resolution	Configurable (10...16 bits)
Degree of protection	IP67*
Approval/Conformity	CE, cULus
Ambient temperature	-5...+70 °C
Housing material	Die-cast zinc
Operating modes (3-wire)	COM2

*when connected

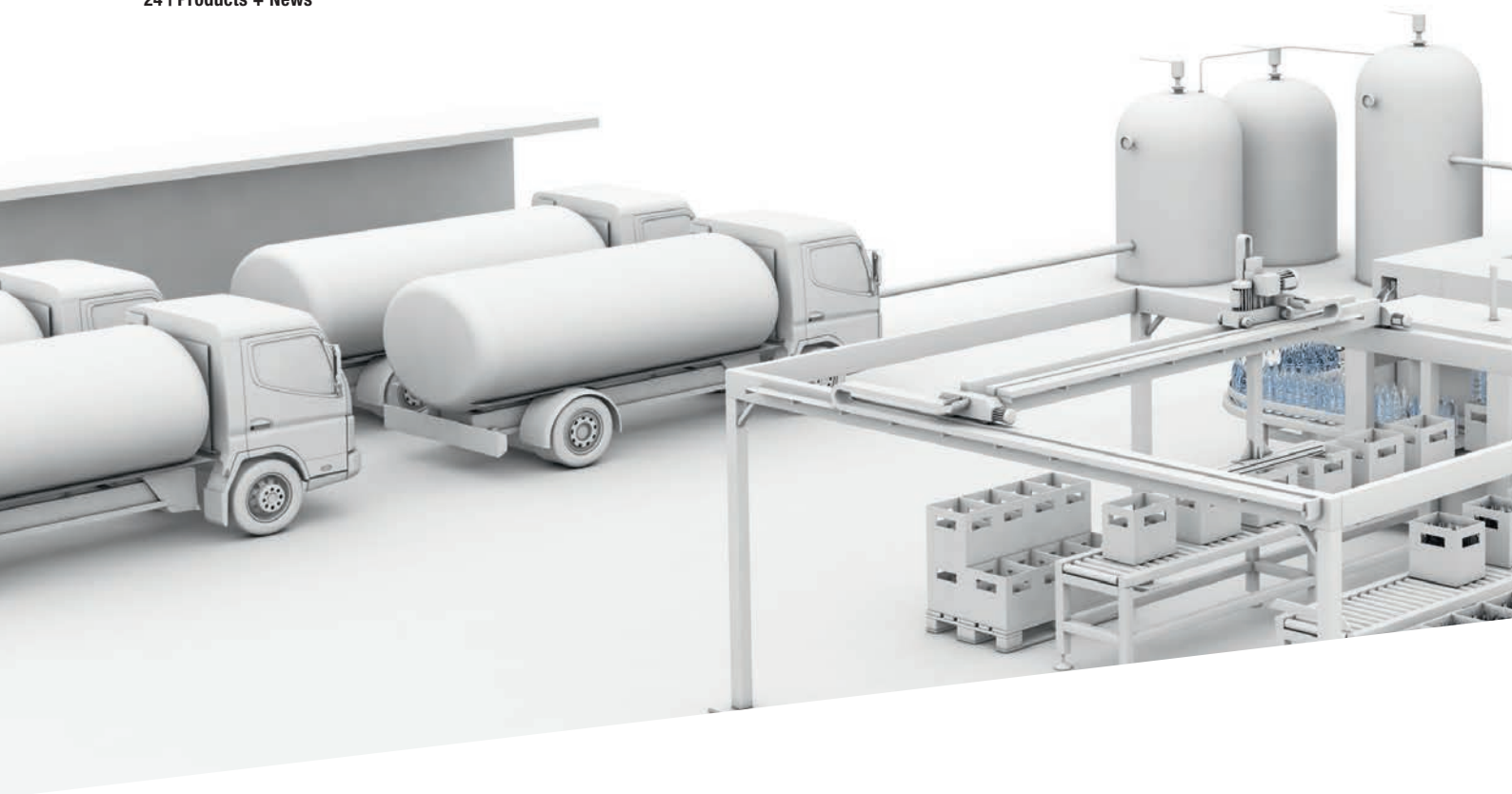

With eight IO-Link ports and cascadable IO-Link I/O hubs

IP69 NETWORK MODULES FOR DEMANDING ENVIRONMENTS



EtherNet/IP PROFINET

IO-Link

IO-Link

	BNI0096	BNI009K	BNI009M	BNI009N
Communication	Ethernet/IP, IO-Link 1.1	Ethernet/IP	Profinet, IO-Link 1.1	Profinet
Design	8 × IO-Link, 16 × I/O	16 × I/O	8 × IO-Link, 16 × I/O	16 × I/O
Communication connection	M12 female, D-coded	M12 female, D-coded	M12 female, D-coded	M12 female, D-coded
Connection: AUX power	7/8" male	7/8" male	7/8" male	7/8" male
Connection: I/O ports	8 × M12 female, A-coded	8 × M12 female, A-coded	8 × M12 female, A-coded	8 × M12 female, A-coded
Degree of protection	IP69*	IP69*	IP69*	IP69*
Approval/Conformity	CE, cULus, Ecolab	CE, cULus, Ecolab	CE, cULus, Ecolab	CE, cULus, Ecolab
Ambient temperature	-5...70 °C	-5...70 °C	-5...70 °C	-5...70 °C
Housing material	Stainless steel 1.4571	Stainless steel 1.4571	Stainless steel 1.4571	Stainless steel 1.4571
Operating modes (3-wire)	COM 1, COM 2, COM 3		COM 1, COM 2, COM 3	

For product finder and more technical details:
www.balluff.com/go/network-blocks

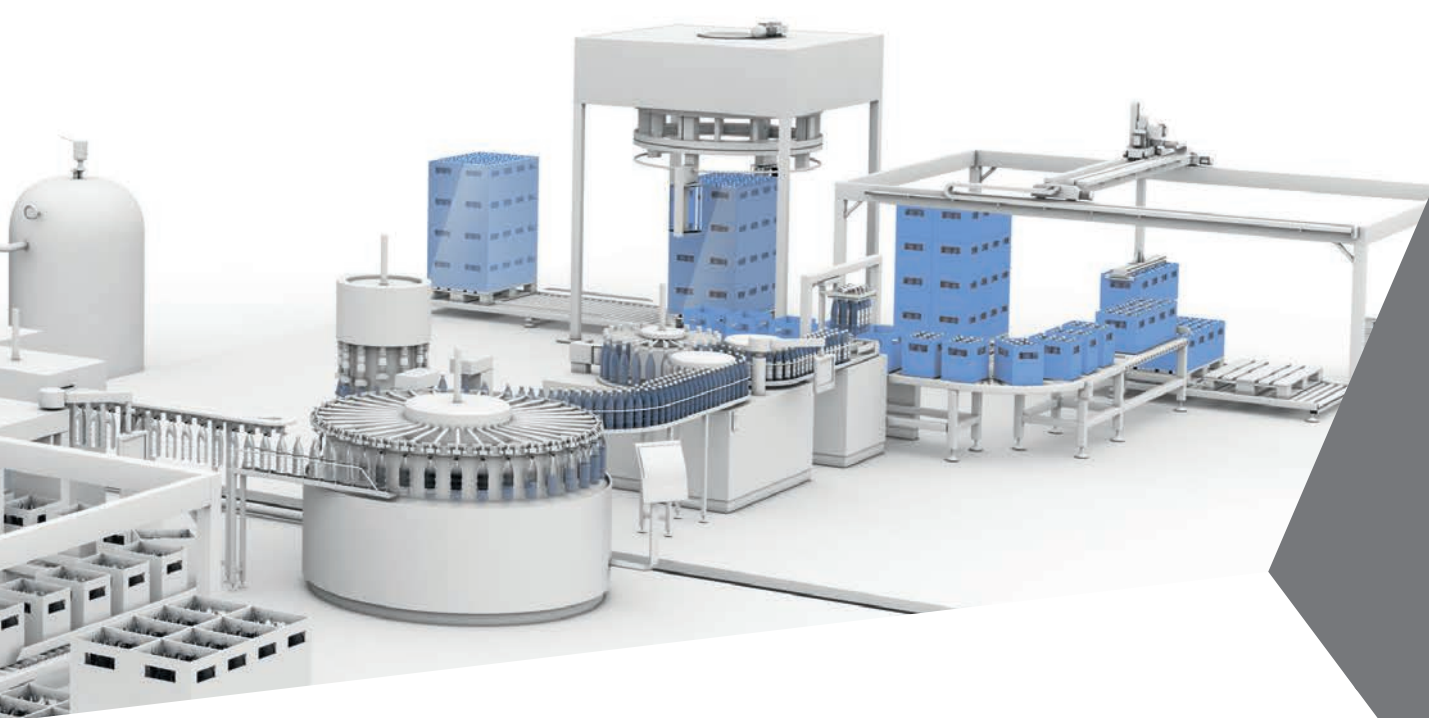

The new network module family in the easy to clean washdown design was developed for the highest hygienic requirements in the food and pharmaceutical industries. Protected by corrosion- and cleaning agent-resistant stainless steel housings, all models guarantee safe and errorless signal transmission even under demanding requirements. The offering includes IO-Link masters with eight IO-Link ports each for 16 in- and outputs, configurable I/O modules as well as IO-Link sensor/actuator hubs. Their technological advantage will convince you: the efficient point-to-point wiring of IO-Link allows construction of a decentralized system architecture outside the control cabinet. And network nodes equipped with an IO-Link master communicate via Ethernet/IP directly with the main controller or control device on the machine.

Features

- Eight IO-Link ports for connecting any IO-Link device up to 16 in- and outputs each with an LED for error diagnostics
- Clearly visible status LED to monitor ports and network communication
- Integrated Web server to show module information (IP address, settings, parameters, ...)
- Expansion port on the IO-Link I/O modules to connect an IO-Link valve interface or an IO-Link sensor/actuator hub increases I/Os to up to 30
- Corrosion- and cleaning agent-resistant housing with IP69 protection
- All network modules Ecolab certified



EtherNet/IP

	BNI009L	BNI00AP	BNI00AR	BNI00AT
Communication	Ethernet/IP	IO-Link 1.1	IO-Link 1.1	IO-Link 1.1
Design	16 × I	16 × I	16 × I/O	16 × I/O
Communication connection	M12 female, D-coded	M12 male, A-coded	M12 male, A-coded	M12 male, A-coded
Connection: AUX power	7/8" male			7/8" male
Connection: I/O ports	8 × M12 female, A-coded	8 × M12 female, A-coded	8 × M12 female, A-coded	8 × M12 female, A-coded
Degree of protection	IP69*	IP69*	IP69*	IP69*
Approval/Conformity	CE, cULus, Ecolab	CE, cULus, Ecolab	CE, cULus, Ecolab	CE, cULus, Ecolab
Ambient temperature	-5...70 °C	-5...70 °C	-5...70 °C	-5...70 °C
Housing material	Stainless steel 1.4571	Stainless steel 1.4571	Stainless steel 1.4571	Stainless steel 1.4571
Operating modes (3-wire)		COM2	COM2	COM2

* when connected

Safe, error-free signal transmission
under extreme conditions

UNIVERSAL IO-LINK INTERFACE

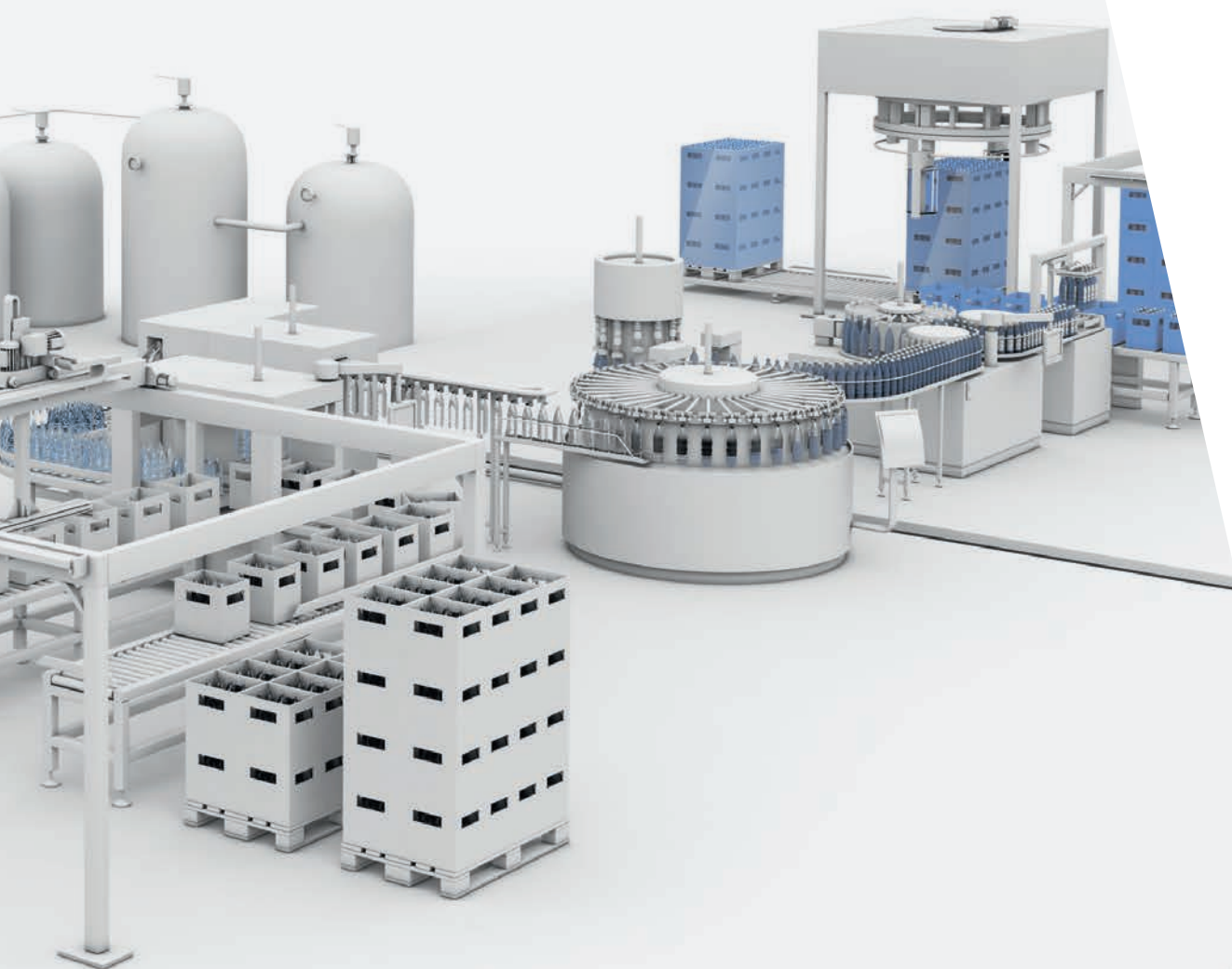

The corrosion- and cleaning agent-resistant IO-Link interface is up to even the most extreme conditions in food and pharmaceutical industries. There, the universal module guarantees safe and error-free signal transmission – no matter how demanding the environment or high the requirements.

The IO-Link interface with up to eight in-/outputs lets you connect things like pumps, signal lights, control panels, valve terminals, as well as switching and transfer units, easily and simply to the control level. The fast IO-Link interface, using standard sensor cable on one hand and the pigtail end with ten conductors on the other, eliminate complex, multiple cable routing. Instead, you use lean cabling concepts and gain space and time while saving money.

Features

- Compact housing can be connected directly to different devices
- IO-Link interface for universal, fieldbus-neutral use
- Connect up to eight in-/outputs
- Easy to install standard sensor cable for linking to the control level
- Corrosion- and cleaning agent-resistant housing with IP69 protection

UNIVERSAL IO-LINK INTERFACES



	BNI00AE
Communication	IO-Link 1.1
Version/number of I/Os, configurable max.	8 × I/O
Operating voltage	18...30.2 V DC, corresponding to EN 61131-2
Connection: IO-Link port	M12 male, A-coded
Operating mode	COM 2
Cycle time	8.4 ms
IO-Link process data length	1 byte input/1 byte output
Max. input load current	1.4 A
Max. load current, output	1 A
Load current per pin	200 mA
Degree of protection	IP69*
Approval/Conformity	CE, cULus, Ecolab
Ambient temperature	-5...+60 °C
Storage temperature	-25...+70 °C
Housing material	Stainless steel 1.4305
Cable length	1300 mm

*when connected

High-quality gear for
virtually any application

ACCESSORIES

 *innovating automation*



Our great selection of high-quality accessories supports you in the optimum embedding of the sensor in machines and systems through easy assembly and installation, exact positioning and high machine availability. The wide Balluff product range offers the optimum gear for nearly every application.

Your Balluff solutions

- Fastening technology
- Lighting for Vision Systems
- Reflectors, fibers, optics
- Mechanical protection
- Communication adapters and signal converters

More light intensity even with diffuse light

COOLANT AND LUBRICANT RESISTANT MACHINE LIGHTS

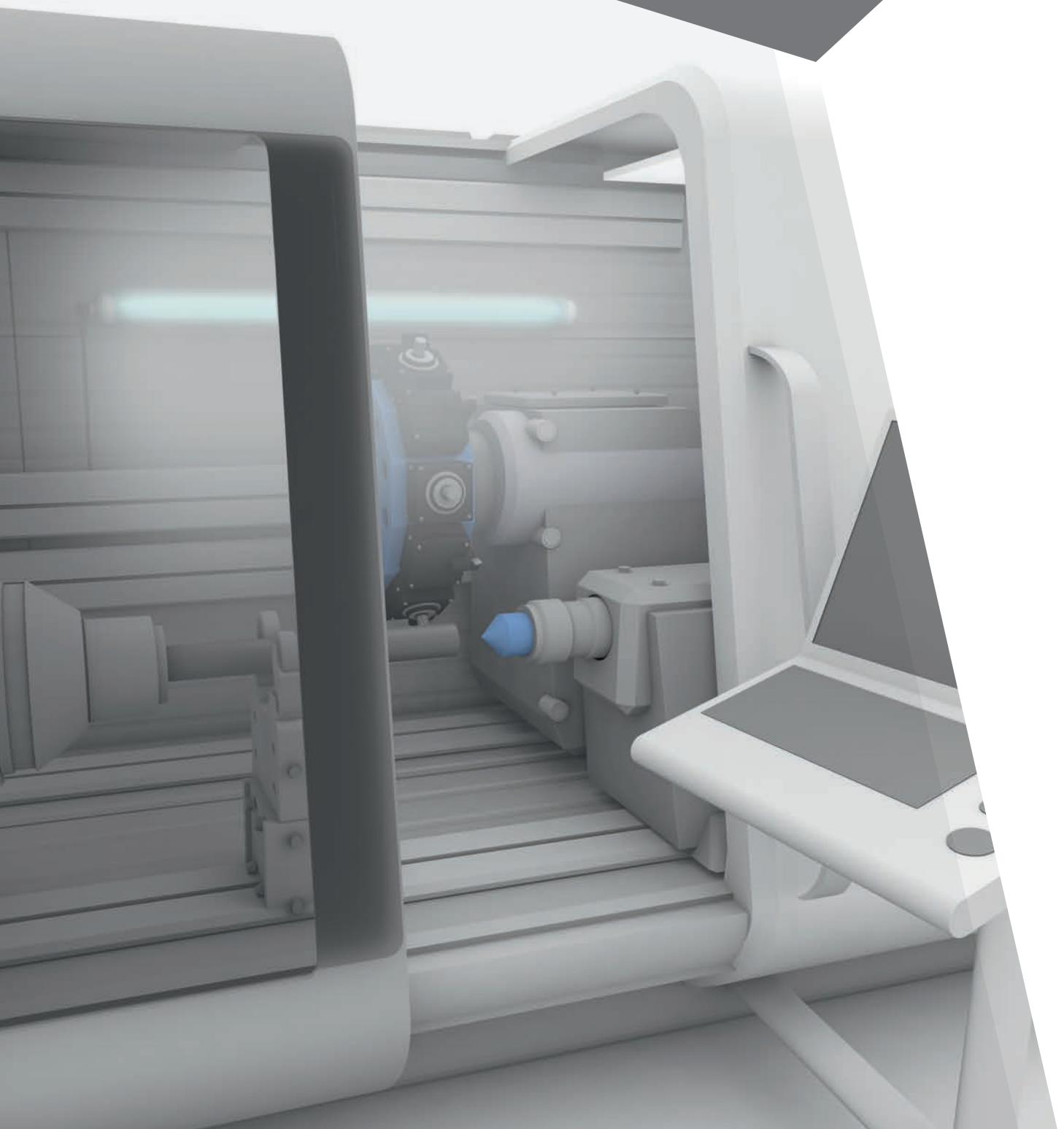

Machine lights with diffuse Ø 45 mm borosilicate glass cover, handle all conceivable standard applications in the automobile industry and production engineering: washing equipment as well as machining centers or semi-automated workstations. Our new portfolio includes five length versions from 420 mm to 1200 mm. All products feature simple installation and the best possible energy efficiency. Even more, their price-performance ratio is more attractive than traditional solutions but often with even better product characteristics.

Features

- Shock- and vibration-proof, thermally and mechanically highly rated
- IP67, suitable for harsh environments
- Inexpensive standard M12 plug-in connection is easy to install
- Diffuser for glare-free, homogeneous and large-area lighting with 5000 K color temperature
- Reduces costs thanks to low energy consumption and high-efficiency LED technology

MACHINE LIGHTING



	BAE00ZM	BAE00ZN	BAE00ZP	BAE00ZR	BAE00ZT
Operating voltage	22...28 V DC	22...28 V DC	22...28 V DC	22...28 V DC	22...28 V DC
Light emission area	380 mm	560 mm	760 mm	960 mm	1160 mm
Port power	12 W	18 W	24 W	30 W	36 W
Illumination	447 lux at 1 m	541 lux at 1 m	675 lux at 1 m	819 lux at 1 m	964 lux at 1 m
Luminous flux	1800 lm	2700 lm	3600 lm	4500 lm	5400 lm
Light type	LED white light, diffuse	LED white light, diffuse	LED white light, diffuse	LED white light, diffuse	LED white light, diffuse
Current consumption	500 mA	750 mA	1 A	1.25 A	1.5 A
Dimensions	Ø 45 × 420 mm	Ø 45 × 600 mm	Ø 45 × 800 mm	Ø 45 × 1000 mm	Ø 45 × 1200 mm
Degree of protection	IP67	IP67	IP67	IP67	IP67
Approvals	CE, EAC	CE, EAC	CE, EAC	CE, EAC	CE, EAC
Ambient temperature	-20...+40 °C	-20...+40 °C	-20...+40 °C	-20...+40 °C	-20...+40 °C
Housing material	Anodized aluminum, borosilicate glass	Anodized aluminum, borosilicate glass	Anodized aluminum, borosilicate glass	Anodized aluminum, borosilicate glass	Anodized aluminum, borosilicate glass
Connection	M12 male, 4-pin	M12 male, 4-pin	M12 male, 4-pin	M12 male, 4-pin	M12 male, 4-pin

Compatible holders can be found on our website

For product finder and more technical details:
www.balluff.com/go/accessories



 *innovating automation*



Balluff

OPENING UP NEW PERSPECTIVES

Balluff is one of the leading suppliers of high-quality sensor, identification and network solutions and of software for your automation requirements. Family-owned for more than 90 years, around 3600 employees worldwide in 37 wholly-owned subsidiaries for sales, production and development are dedicated to the highest quality.

We give our all to provide top services for innovative solutions that increase your competitive edge. Through years of experience we bring the competence of a manufacturer and high personal engagement.

We follow our motto "Innovating Automation" as pacemakers of automation, refiners and new developers, and technological trailblazers. In open exchange with associations, universities and research institutes, as well as in close contact with our customers, we create new industrial sector solutions for automation. With innovative Balluff solutions, you are well equipped for a successful future.

You can always count on us, our products and our scheduling and delivery reliability. In the spirit of a good partnership.

Global project management

WE ARE EVERYWHERE FOR YOU

Always where you need us

Wherever you are doing business, we will support you locally. We work closely with machine and systems builders, systems integrators, planning offices and maintenance engineers. Balluff has constructed a global network for you consisting of technical consulting, sales and after-sales services.

Project manuals and approval lists

We provide you with custom tailored product data for smooth running of your projects. You receive project-specific manuals and approval lists. And personal contacts from Balluff are at your side throughout the entire project.

Individual services

If our services need to be even more personalized, we make this possible as well: with individual e-catalogs, application-specific product modifications, integrated software and system solutions and comprehensive logistics concepts.

Questions? Contact us. We are happy to help.



 *innovating automation*

Headquarters
Balluff GmbH
Schurwaldstrasse 9
73765 Neuhausen a. d. F.
Germany
Phone +49 7158 173-0
Fax +49 7158 5010
balluff@balluff.de



www.balluff.com

CONTACT OUR
WORLDWIDE
SUBSIDIARIES